

# Dedileo incasso

# Dedileo recessed

ISTRUZIONI PER L'INSTALLAZIONE  
INSTRUCTIONS FOR INSTALLING  
MODE D'INSTALLATION  
MONTAGEANWEISUNGEN  
INSTRUCTIES VOOR HET INSTALLEREN  
INSTRUCCIONES PARA INSTALACION

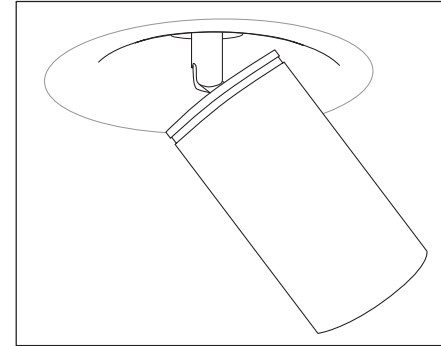

**ATTENZIONE:**

La sicurezza dell'apparecchio è garantita solo dall'uso appropriato delle seguenti istruzioni, pertanto è necessario rispettarle e conservarle.

**WARNING:**

Device security is guaranteed by the appropriate use of the following directions, therefore it is required to follow and to keep them.

**ATTENTION:**

La sécurité de l'appareil n'est garantie que dans le respect des instructions suivantes, Nous vous conseillons donc de les bien conserver.

**ACHTUNG:**

Die Gerätsicherheit ist versichert unter der Voraussetzung, daß die folgenden Einleitungen richtig verwendet und eingehalten werden. Deshalb ist es notwendig, sie zu bewahren

**ATTENTIE:**

De veiligheid van het armatuur is alleen gegarandeerd bij het juist toepassen van de volgende montage-voorschriften.

**ATENCION:**

La seguridad del aparato se garantiza solo cumpliendo cuidadosamente las siguientes instrucciones; por ello, es necesario conservarlas.



**I** Apparecchio predisposto per il montaggio diretto su superfici normalmente infiammabili.

**GB** Device fitted for directly mounting onto normally inflammable surfaces.

**F** Appareil réalsépour le montage direct sur superficies normalement inflammables.

**D** Leuchte geeignet zur Montage auf normalerweise Flächen.

**NL** Toestellen voorzien voor montage op normaal brandbare oppervlakten.

**E** Aparato preparado para ser montado directamente en superficies inflamables.



**I** Apparecchio di classe II

**GB** Class II luminaire

**F** Appareil de classe II

**D** Garat Klasse II

**NL** Toestellen van Klasse II

**E** Aparato de clase II

**I** Gruppo di rischio 1, secondo norma EN 62471:2008

**GB** Risk group 1, in compliance with standard EN 62471:2008

**F** Groupe de risque 1, suivant la norme EN 62471:2008

**D** Risikogruppe 1, gemäß Vorschrift EN 62471:2008

**NL** Risicogroep 1, volgens de norm EN 62471:2008

**E** Grupo de riesgo 1, según norma EN 62471:2008



**I** L'apparecchio non deve, in alcuna circostanza, essere coperto con materiale isolante.

**GB** The fixture must not be covered, under any circumstances, by insulating materials or like.

**F** L'appareil ne doit, en aucun cas, être couvert par un matériau isolant ou autre.

**D** Das Gerät darf auf keinen Fall mit Isoliermaterial oder ähnlichem bedeckt werden.

**NL** Het apparaat mag in geen geval bedekt worden met isoleringsmateriaal of dergelijke.

**E** El aparato no debe ser protegido con material aislante o parecido, por ninguna causa.



Ø140mm

