

Miniline

ISTRUZIONI PER L'INSTALLAZIONE
INSTRUCTIONS FOR INSTALLING
MODE D'INSTALLATION
MONTAGEANWEISUNGEN
INSTRUCTIES VOOR HET INSTALLEREN
INSTRUCCIONES PARA INSTALACION

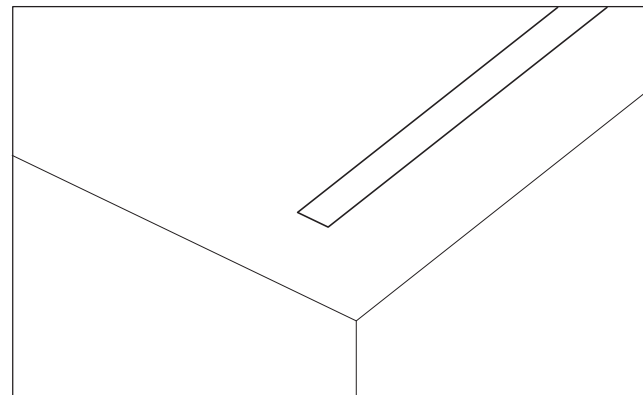

ATTENZIONE:

La sicurezza dell'apparecchio è garantita solo dall'uso appropriato delle seguenti istruzioni, pertanto è necessario rispettarle e conservarle.

WARNING:

Device security is guaranteed by the appropriate use of the following directions, therefore it is required to follow and to keep them.

ATTENTION:

La sécurité de l'appareil n'est garantie que dans le respect des instructions suivantes, Nous vous conseillons donc de les bien conserver.

ACHTUNG:

Die Gerätsicherheit ist versichert unter der Voraussetzung, daß die folgenden Einleitungen richtig verwendet und eingehalten werden, Deshalb ist es notwendig, sie zu bewahren

ATTENTIE:

De veiligheid van het armatuur is alleen gegarandeerd bij het juist toepassen van de volgende montage-voorschriften.

ATENCIÓN:

La seguridad del aparato se garantiza solo cumpliendo cuidadosamente las siguientes instrucciones; por ello, es necesario conservarlas.



I Apparecchio predisposto per il montaggio diretto su superfici normalmente infiammabili.

GB Device fitted for directly mounting onto normally inflammable surfaces.

F Appareil réalisé pour le montage direct sur superficies normalement inflammables.

D Leuchte geeignet zur Montage auf normalerweise Flächen.

NL Toestellen voorzien voor montage op normaal brandbare oppervlakten.

E Aparato preparado para ser montado directamente en superficies inflamables.



I Apparecchio di classe III

GB Class III luminaire

F Appareil de classe III

D Gerät Klasse III

NL Toestellen van Klasse III

E Aparato de clase III

